

# Travel End stop installation instructions

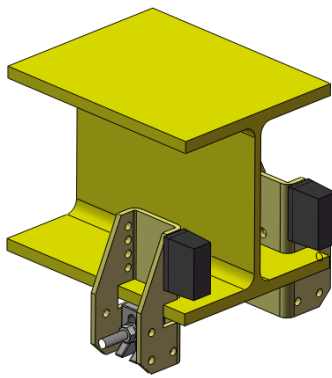

Buffer Block A  
 ( 2 Different heights )

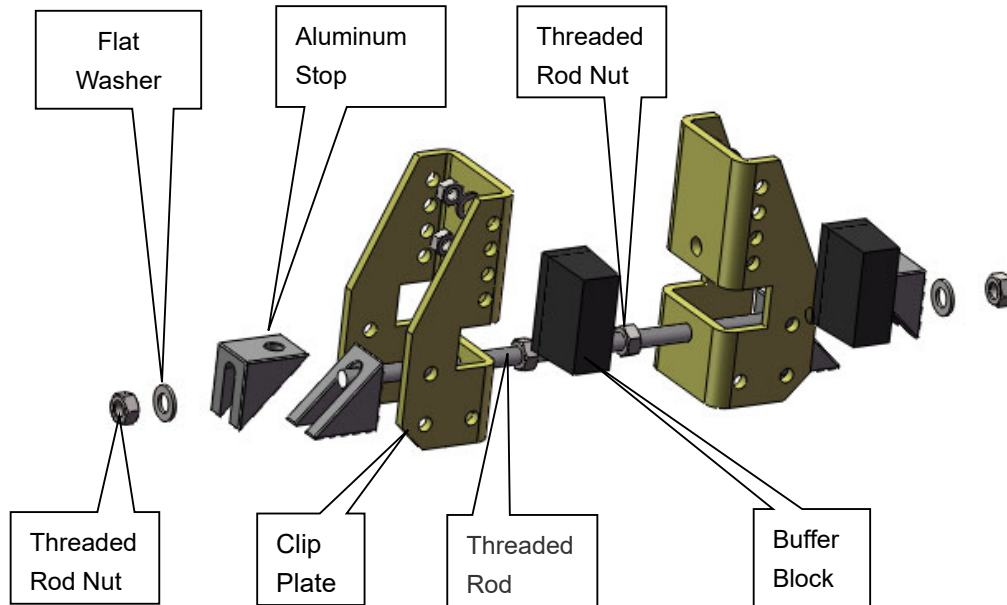
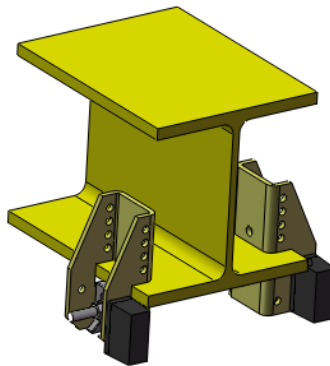

Buffer Block B

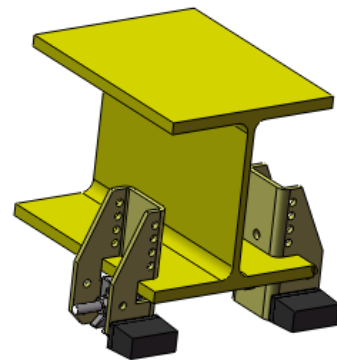

Buffer Block C

**Each set of end stops includes the following components:**

**Clip plate x4, Threaded Rod x2, Buffer block x4, Aluminum stop x8, Nut x8, Flat washer x8, Wrench x1.**

## Installation steps:

1. Install two nuts and flat washers in the middle of the threaded rod.
2. Hold the two clip plate's on the track beam and simultaneously install the threaded rod.
3. Install two aluminum stop's on each end of the threaded rod in accordance with the direction shown.
4. Lock the aluminum stop's with nuts and washers.
5. Adjust and lock the two nuts in the middle of the threaded rod to the inside of the two clip plate's.
6. Based on individual requirement's , install the buffer block on the clip plate and secure it with the nut in any of the 4 positions shown above.