

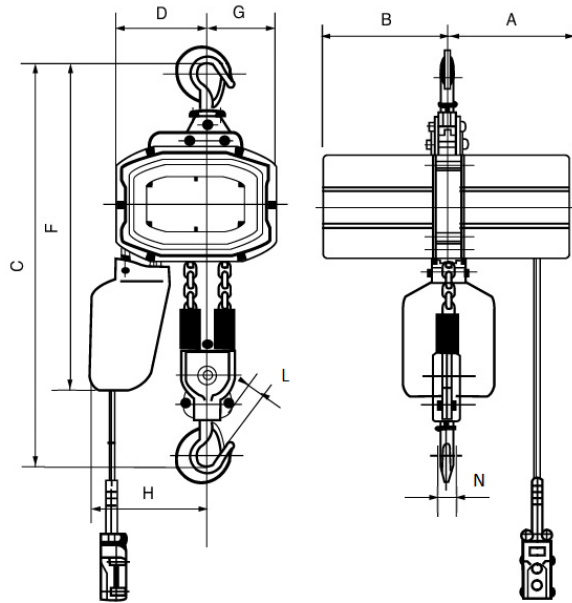

# BISON

LIFTING EQUIPMENT



2 TON

Product Code:	Cap.	Standard Lift Height	Lifting Speed	Motor Output	Power Supply	Control Voltage	Rated Current (amps)		Load Chain Size	Chain Fall Lines	Pendant Cord Length	Total Net Weight
	Tons	Ft.	Ft./min	Hp.	Volts (1-Phase)	Volts	@115v	@230v	mm		Ft.	Lbs.
HH-B20	2	20	10.5	2	115/230V	24	14.2	7.1	7.1	2	17	173

Product Code	Cap.	Head Room (C)	A	B	G	D	L	F	H	N
	Ton	Inches	Inches	Inches	Inches	Inches	Inches	Inches	Inches	Inches
HH-B20	2	29.1	10	10	7	5	1.65	26	9	0.83