BIH Series VFD Electric Chain Hoist

User Manual and Maintenance Procedures



Description

Thank you for buying our BIH Series Electric Chain Hoist, please keep this manual handy for periodic maintenance and troubleshooting information. Before installation and use, be sure to read and understand the safety and care instructions mentioned in this User Manual carefully. Follow all Warnings and Safety Procedures. Ensure that the person operating the hoist has carefully read and understood the contents of this User Manual before operation.

Please note: This product User Manual is subject to change without notice.

Technical Parameters

Model number	BIH series	
	040	050
Voltage	120V, 60Hz	
Rated power	0.6 HP	1.4 HP
Rated current	7A	15A
Rated Capacity	400 lbs	(1,000 lbs) ½ Ton
Lifting speed	0-30 ft/min	0-33 ft/min
Lifting height	16 ft	
Chain diameter	4.0mm	6.3mm
Duty Class	H4	
Ingress Protection	IP54	
Duty Rating	50% ED	
Working temperature range	32° - 104°F	
Net weight	37 lbs	79 lbs

Warnings

- (1) After removing the hoist from its box, carefully check the body of the hoist for any damage or defects. Visually inspect the pendant cable, hook, chain and in-line control handle for any damage during transport.
- (2) Ensure there is no dirt or debris on the load chain, check for kinks and knots in the chain. If the chain looks in good condition and is free of debris, attach the included suspension bar or top hook using the hardware provided. Please note it is not recommended to use the hoist without a thorough inspection of the chain first.
- (3) Ensure that pendant cable is free of obstruction from rotating or moving objects and there are no knots or kinks in the cable that could interfere with the load chain.
- (4) Do not leave the hoist unattended during operation or once a load has been lifted. Ensure the hoist does not remain under load while not in use.
- (5) This hoist is not for use in the rain or in extreme damp conditions. This hoist is not for use in explosive, flammable, or corrosive environments.
- (6) When the hoist is lifting or lowering, ensure that personnel do not move within the area of operation to prevent accidents.
- (7) This hoist should not be used for handling hot melts and should not be used in hazardous or extreme temperature environments.

Safety Guidelines

Before using this hoist, be sure to read and follow all safety guidelines:

1. Do NOT lift more than rated load of the hoist.
2. Do NOT use twisted, knotted, damaged, or worn chains.
3. Do NOT Operate a hoist which has been modified without the manufacturer's approval or without certification that it is in conformity with ANSI/ASME B30 volumes.
4. Do NOT Operate this hoist above or below the working temperature range (32°-104°F)
5. Do NOT attempt to lift more than the rated load capacity, this will cause the hoist to stop and an overload fault code to appear. When the lifting load exceeds the rated value, error code 'Ea: 1' appears on the handle display, pressing the Down button will open an expanded view of this error. If this situation occurs, stop use of the hoist immediately and reduce the load to below the rated capacity. When the overload is removed, the hoist can operate normally.
6. Do NOT exceed rated duty cycle of 50% - 10 min (i.e., 5 min of work followed by 5 min of rest). Do not use continuously. Continuous use of this hoist may lead to damage.
7. Do NOT operate unless load is centered directly under hoist.
8. Do NOT operate hoist when it is restricted from forming a straight line from hook to hook in the direction of loading.
9. Do NOT attempt to lengthen the load chain or repair damaged load chain.
10. Do NOT lift or move loads over people
11. Do NOT operate hoist unless all persons are and remain clear of the supported load.
12. Ensure the emergency stop is engaged when the hoist is left unattended.
13. Do NOT use load chain as a sling or wrap load chain around load.
14. Do NOT operate beyond the limits of the load chain travel.
15. Do NOT use the hoist to lift, support, or transport people.
16. Do NOT remove or obscure the warnings on the hoist.
17. Do NOT operate a hoist on which the safety placards or decals are missing or illegible.
18. Only use the provided hardware to mount or suspend the hoist.
19. Do NOT use the tip of the hook to support the load.
20. Do NOT use a hoist if the hook latch is missing or broken.

Installation

1. Before using the hoist, ensure the mounting hardware is attached as pictured in Figure 1-A

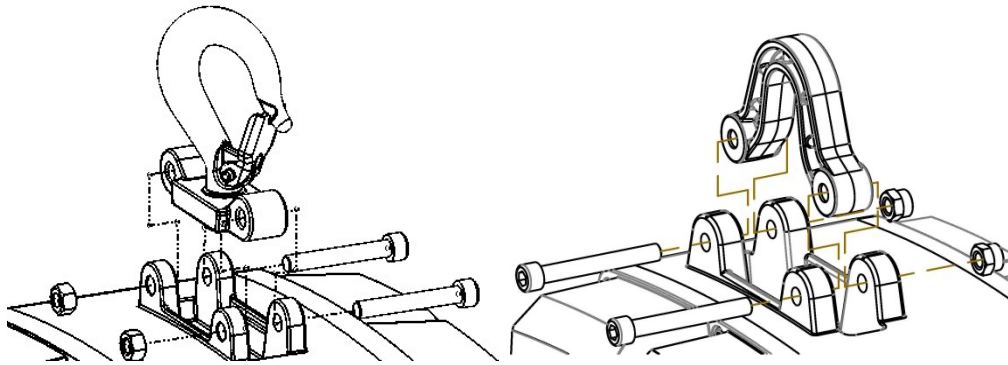

Figure 1-A
BIH-TH (Top Hook) & BIH-SB (Suspension Bar)

2. Be sure that your mounting point and its structure can support the weight of the hoist and its rated capacity. Ensure the provided hardware is used when mounting your hoist. Ensure the mounting components are installed correctly.
3. The standard power supply for the hoist operation is single-phase AC 120 (V)/60 (Hz) and must use a power supply with a ground.

Do NOT alter or modify the plug connector in any way.

Introduction of Components: See Figure 2

1. Upper hook or Suspension bar
2. M8 self-locking nut
3. Main body
4. Power cord
5. M8 X 55mm internal hex bolt
6. Chain bag
7. Intelligent handle

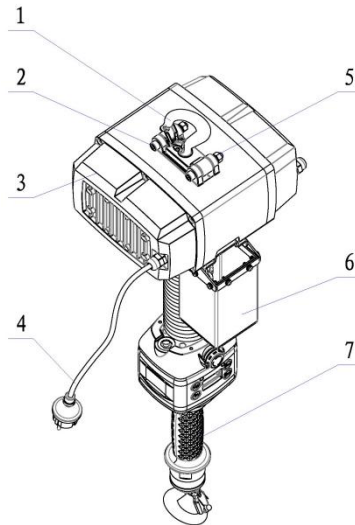

Figure 2

Introduction of BIH Series Intelligent Electric Chain Hoist Operating Handle

Operating handle: See Figure 3

1. Emergency stop switch: Pressing the emergency stop switch will engage the emergency stop function preventing the hoist from operation, to disengage, rotate the emergency stop switch clockwise. The button will extend and disengage the emergency stop function, allowing the hoist to operate as normal.
2. Emergency stop indicator light: This light illuminates when emergency stop is engaged.
3. Escape key: Exit menu option. Press while load is suspended to manually enter and exit float mode.
4. Enter key: Confirm menu option. Press to enter the settings menu, and Press & Hold button to enter the weight calibration function.
5. IR Grip Sensor: Activates manual operation mode and allows the hoist to be controlled by the in-line pendant. The in-line control pendant will not activate unless the IR grip sensor detects a hand within the upper half of the control handle. If the IR Grip sensor is activated during float mode, the hoist will automatically return to manual operation mode and exit float mode.
6. Power indicator light: Signals when the hoist is powered on.
7. Up key: for navigating menu options and setting values when adjusting limits.
8. Down key: for navigating menu options and setting values when adjusting limits. During normal operation mode, press this key to display fault analysis mode.
9. Display screen: displays the menu information in settings and real time weight during normal operation.
10. Control handle: control the lifting and acceleration functions in normal operation mode. Lifting and lowering speeds vary as the distance between the upper and lower handles changes. Activating the control handle while in float mode will take the hoist out of float mode.

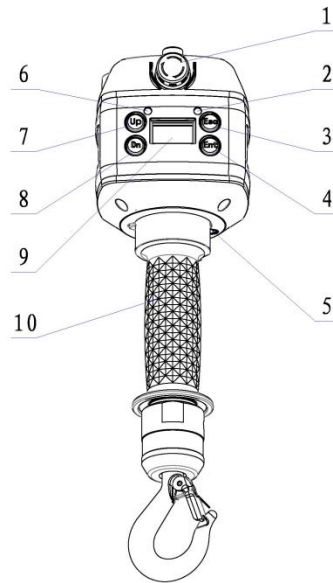
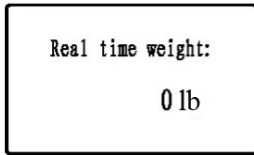

Figure 3

- | | | | |
|--------------------------|-----------------------------------|---------------|--------------|
| 1. Emergency stop switch | 2. Emergency stop indicator light | 3. Escape key | 4. Enter key |
| 5. IR Grip sensor | 6. Power indicator | 7. Up key | 8. Down Key. |
| 9. Display screen | 10. Control handle | | |

Introduction of BIH Series Intelligent Electric Chain Hoist

The BIH series intelligent electric chain hoist is on after connecting to power, and the display screen shows the real-time weight of the load, with the weight in lbs.



Real time weight: 0 lbs

Press the emergency stop switch for safety when setting the hoist's functional parameters and securing a load to the hook, this will illuminate the emergency stop light and the error 'Ea: 12' will appear on the upper edge of the display screen, as shown below

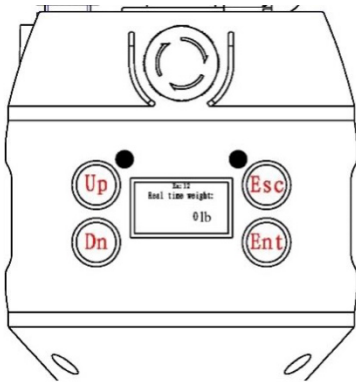

Real time weight: 0 lbs

Press Ent to enter the setting interface. There are five functional options in the setting interface, which are: 1 coaxial zeroing; 2 Speed setting; 3 Suspension setting; 4 Virtual limit setting; 5 language.

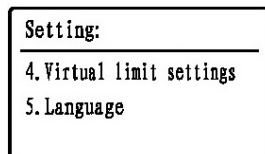
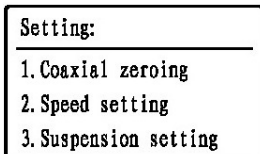

1. Coaxial zeroing: the first startup requires coaxial zeroing, calibrating the hoist for normal lifting and lowering. In this setting interface once the handle is vertical and still, press Enter to calibrate the coaxial zeroing setting successfully.

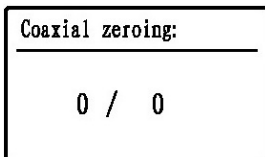

2. Speed setting: refers to the maximum speed setting for lifting and lowering during normal operation.
3. In this setting each level (1-10) represents 10% of the maximum allowable speed. Level 1 Being the lowest max speed at 10% of the full speed range and level 10 being 100%.
Once you've adjusted this setting using the Up and Down key, press Enter to store the setting.

Speed setting:
1. Rise speed
2. Descending speed

Rise speed: 10
10

Descending speed: 10
10

Please note: You can have separate maximum speed settings for lifting and lowering.

Float Mode

To manually enable float mode, first return to normal operation mode where the real time weight is displayed. Press the Escape key to activate float mode. The "F" icon will appear on the screen, this indicates that float mode has started, as shown in the figure below:

Real time weight:
F 0 lb

Warning: Do not change the weight of the load while in float mode. Adding more weight while in float mode will cause the load to drop; removing weight from the load will cause the load to rise. The speed of this unwanted movement is directly proportionate to the weight added or removed, this may cause injury to personnel or damage to the load.

3. Suspension setting: the setting of various float mode parameters. This menu includes 5 sub-menus: Sensitivity setting, Start-stop threshold, Preventing rebound, Weight change Protection, and Auto Suspension.

Suspension setting:
1. Sensitivity setting
2. Start-stop threshold

3.1 Sensitivity setting: This setting allows you to increase or decrease the sensitivity to match the weight of the load. The greater the weight of the load the lower you'll want to set the sensitivity to avoid accidental activation of the motor. For light loads a higher sensitivity is required to maintain responsiveness. Please note this setting only applies to float mode.

3.2 Start-stop threshold: This setting sets the aggressiveness of the brake once applied force stops.

- A setting of 0 allows for a longer and smoother deceleration once applied force has stopped. This is good for loads that require gentle stops.
- A setting of 10 applies the brake in shortest amount of time after applied force has stopped. The load will come to a stop quicker but still provides a slope or ramp down of speed so as not to jostle the load.

3.3 Preventing Rebound: Enabling this setting will allow a load to be lowered to the ground in float mode without any additional movement.

3.4 Weight Change Protection: This setting sets the maximum weight change allowed during float mode, making a change in weight beyond this limit prevents the motor from activation and takes the hoist from float mode back to normal operation. Use this setting to prevent accidental activation due to unsecured load slipping off the hook or other external forces moving the load up or down in error.

Please note: Do NOT operate this hoist without first securing the load to prevent shifting or changes in the weight of the load, doing so could cause drifting or injury.

3.4 Auto Suspension: This setting will allow you to set the activation, error allowance and time required before automatically entering into float mode.

1. Enable/Disable setting
2. Error: this sets the maximum allowable variance in weight before allowing the hoist to enter auto suspension mode from normal operation.
3. Time: This sets the minimum amount of delay experienced in seconds before the hoist goes into float mode automatically from normal operation mode.

4. Virtual limit setting: These settings allow you to fine tune the limit range. The menu consists of five submenus: Upper virtual limit setting, Lower virtual limit setting, Upper virtual limit enable, Lower virtual limit enable, and Virtual limit fine adjustment.

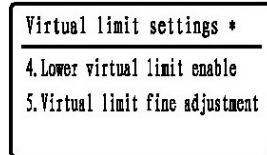
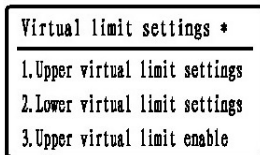

4.1 Upper virtual limit setting: Selecting this option will allow you to move the hook up or down using the control handle and pressing Enter to set the uppermost limit in lifting range where the hook currently is at the time.

(see 4.3 to enable/disable this limit)

When the hook reaches the upper limit of this range the upper right corner of the display will show the 'Virtual Upper Limit' icon (seen below). This will stop the hook from going any higher and will only allow you to lower the hook from that point.

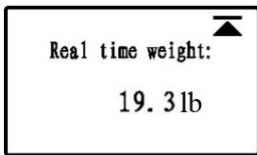

4.2 Lower virtual limit setting: Selecting this option will allow you to move the hook up or down using the control handle and pressing Enter to set the lowermost limit in lifting range where the hook currently is at the time.

(see 4.4 to enable/disable this limit)

When the hook reaches the lower limit of this range the upper right corner of the display will show the 'Virtual Lower Limit' icon (seen below). This will stop the hook from going any lower and will only allow you to raise the hook from that point.

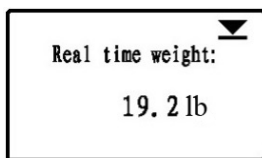

4.3 Upper virtual limit enable: Use the Up and Down to Enable or Disable the Virtual Upper Limit you set in 4.1 Press Enter to store this setting.

4.4 Lower virtual limit enable: Use the Up and Down to Enable or Disable the Virtual Upper Limit you set in 4.2 Press Enter to store this setting.

4.5 Virtual limit fine adjustment: This setting allows you to adjust the range of upper and lower limits using the Up and Down keys. First, using the control handle navigate to either your upper or lower virtual limit. Then open this setting in the menu, now you can use the Up and Down keys to raise or lower your entire limit range

Please note: moving the 'Virtual limit fine adjustment' will move both of your limit stops as a range and will not allow you to change upper and lower limit settings individually. The only way to do that is to use the Upper or Lower Virtual Limit settings (4.1 or 4.2.)

4.6 BIH Series Chain hoist is equipped with physical upper and lower limiting devices. Physical upper or lower limit symbol is shown in the upper right corner of the figure below:

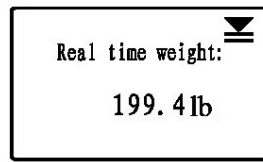
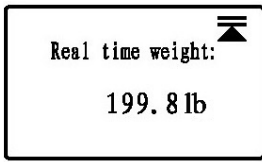

Physical Upper limit symbol displayed

Physical Lower limit symbol displayed

5. Language: Select the language used by the system, optional: Chinese and English.

6. Weighing calibration: Press and hold the Enter key (about 1.5 seconds) to enter the weighing calibration interface, which has three sub-menus: 1 coarse adjustment; 2 fine adjustment; 3 weight zeroing

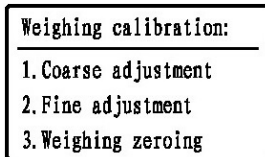

If the weight displayed during normal operation is inaccurate, it can be calibrated according to the following steps:

1. With no load attached, enter the weighing zeroing option and press Enter key to zero or tare the weight of the hook.
Please note: If you would like to zero or tare the weight of equipment used to secure the load to the hook, follow this step once the equipment is attached.
2. Before the displayed weight is accurate you must calibrate it by adding a known weight to the hook and adjusting the Coarse and Fine adjustment settings in the weight calibration mode. Increasing or decreasing the values of coarse adjustment will show a large difference in the displayed weight. Once you get as close as you can to the known weight of the object, use the fine adjustment setting to get a finer degree of control to adjust the displayed weight to the exact known weight. Press Enter key to save this setting, then press Escape key to exit calibration mode.

The system will show you how far you have adjusted the Coarse or Fine adjustment setting in the upper right corner. Please note: if Fine adjustment is set higher than 60, please continue to use coarse adjustment to get closer to the final weight, keeping fine adjustment setting lower in the 40-50 range

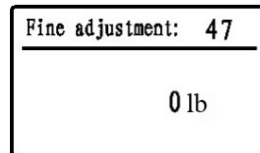
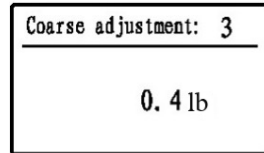
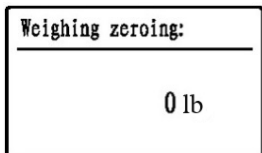

Chain Lubrication

New Hoists:

Before putting the hoist into operation make sure you thoroughly lubricate the chain with the oil supplied with the hoist in a small container in the packing crate. It is very common for a user to install a new hoist and make the mistake of not lubricating the chain, this quickly leads to hoist making noise or for metal shavings to fall from the hoist because the chain has been operated dry and is now damaged.

Once enough damage has occurred, it is too late to salvage the chain, requiring replacement of your new load chain.

A good quality machine or gear oil should be used to Grade ISO VG46 or 68.



Chevron Rando HD 46



Shell Tellus S2 MX 46

A Dry Lube such as CRC Dry Moly Lube can be used, found on Zoro, Amazon, MSC, Fastenal, and many other websites.



Maintenance Measures

You **MUST** periodically inspect for loose bolts nuts or rivets. Search for any evidence of wear, corrosion, or distortion, in the body, suspension bolts, load chain, and in power cords and promptly remove dust, water, and corrosive fluids that have accumulated on any part of the hoist.

Lubricating oil

A new BIH Series electric chain hoist is outfitted with a lifelong machine grease. During operation of the hoist, there may be a small amount of grease oozing, especially during the first use. This is normal and does not require the adding of any grease or lubricant to the chain hoist.

Chain

You **MUST** regularly inspect the chain components of the BIH Series electric chain hoist, and stop use if there are any of the following defects in the chain such as notches, pits, twists or kinks in the chain, welding slag, corrosion, cracks,, wear and stretched links. As shown in the figure:



Chain specification is as follows:

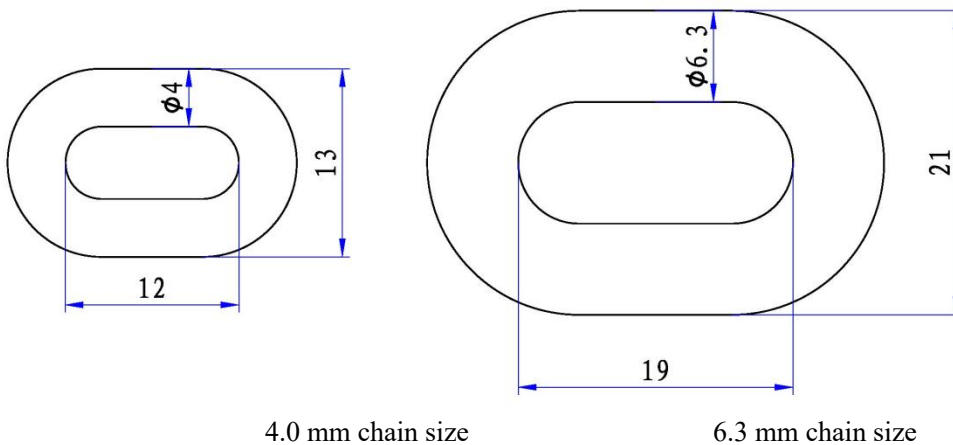

4.0 mm chain size

6.3 mm chain size

Do **NOT** replace or modify the chain in any way.

Inspection of upper and lower hook:

The signs of damage to be on the lookout for when it comes to load hooks are corrosion, deformation, fracture, or distortion greater than 10° compared to a normal hook, enlarged hook opening, etc., which indicate improper use or overload of the hook. Be sure to check the hook safety latch to make sure it is not damaged or bent and remains closed when in use.

BIH-040 Intelligent Electric Chain Hoist Exploded View Diagram

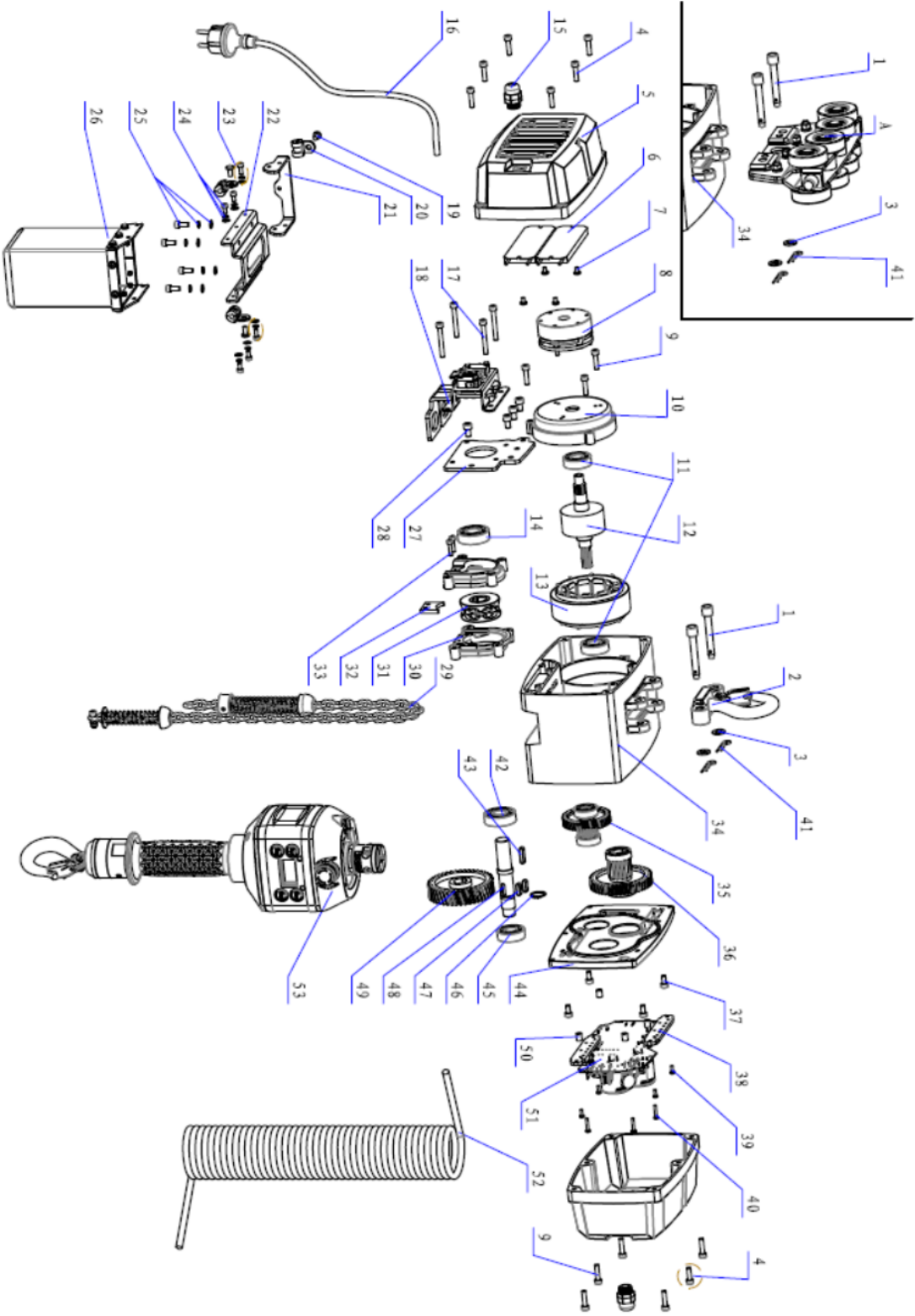

Details of BIH-100&200 Intelligent Electric Chain Hoist Explosion Diagram

No.	Components	Quantity	No.	Components	Quantity
1	Fixed pin	2	33	Hexagon socket cap screws M4*16	2
2	Hook assembly	1	34	Housing	1
3	Lock nut M8	2	35	Primary gear assembly	1
4	Hexagon socket cap screws M5*20	7	36	Secondary gear assembly	1
5	Cover	2	37	Hexagon socket cap screws M5*10	4
6	Resistance	2	38	Heat dissipation plate	2
7	Cross recess head screw M4*6	4	39	Cross recess head screw M3*8	4
8	Brake	1	40	Cross recess head screw M3*16	4
9	Hexagon socket cap screws M5*30	8	41	Cotter pin	2
10	Motor rear cover	1	42	Rolling bearing 6203-2RS	1
11	Rolling bearing 6202-2RS	2	43	Flat key 5*22	1
12	Rotor	1	44	Gear box cover	1
13	Stator	1	45	Rolling bearing 6202-2rs	1
14	Rolling bearing 6203-2ZN + stop ring d40	1	46	Bearing seal d17	1
15	Cable gland M16	2	47	Flat key 5*16	2
16	Plug	1	48	Chain wheel axle	1
17	Hexagon socket cap screws M5*45	4	49	Tertiary gear wheel	1
18	Limit assembly	1	50	Spacer	4
19	Cross recess head screw M5*10	3	51	Main control board	1
20	Cable buckle	3	52	Pendant Cable	1
21	Pendant Cord Mounting Plate	1	53	Smart coaxial slide handle assembly	1
22	Chain bag base	1	54		
23	Hexagon socket cap screws M4*10	2	55		
24	Hexagon socket cap screws M4*8	4	56		
25	Hexagon socket cap screws M5*12	4	57		
26	Chain bag assembly	1	58		
27	Support plate	1	59		
28	Hexagon socket cap screws M6*14	4	60		
29	Chain assembly	1	61		
30	Chain wheel holder	2	62		
31	Chain wheel	1	63		
32	Chain baffle	1			

BIH-050 Intelligent Electric Chain Hoist Exploded View Diagram

BIH-050

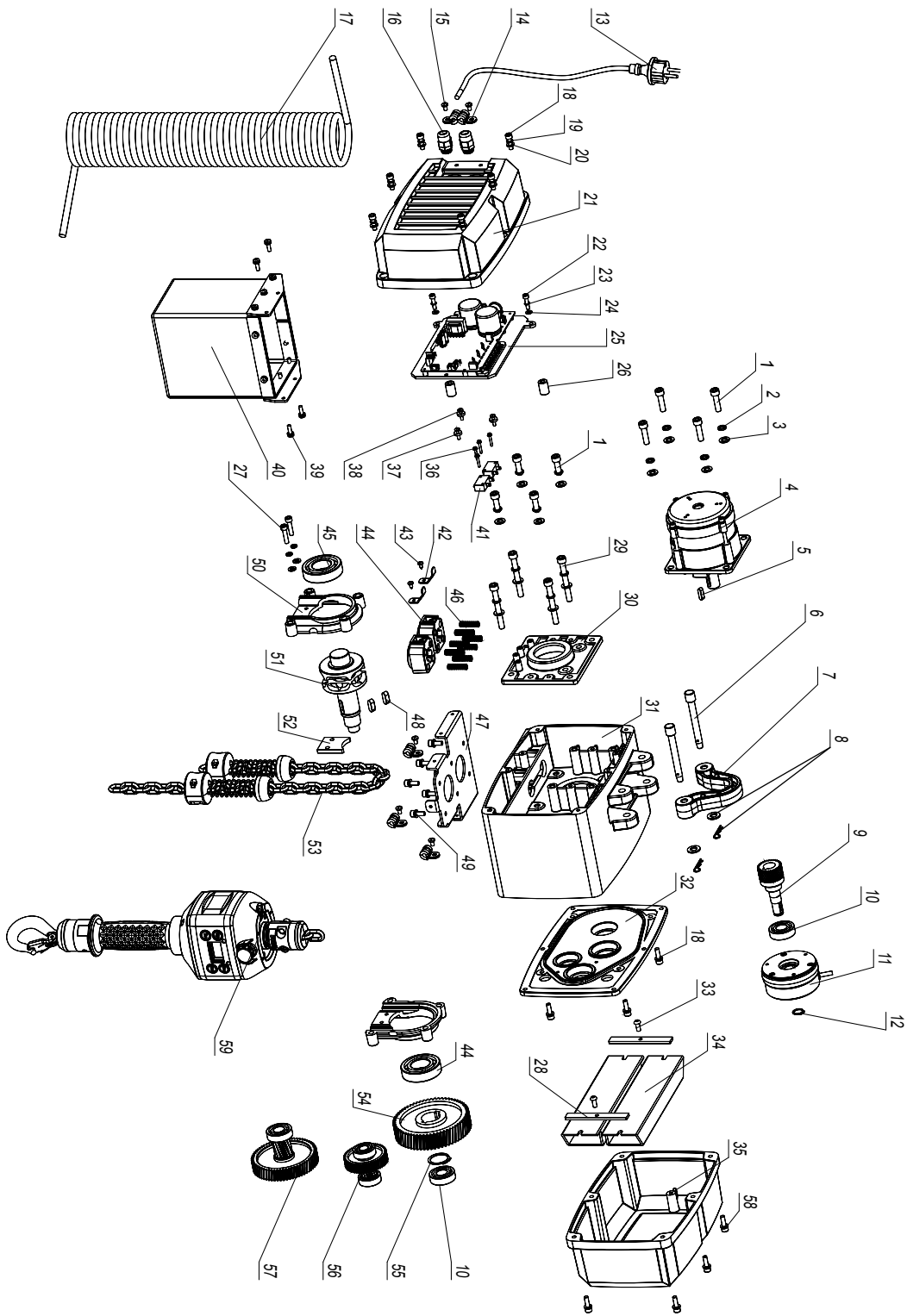

Details of BIH-250&500 Intelligent Electric Chain Hoist Explosion Diagram

No.	Components	Quantity	No.	Components	Quantity
1	Hexagon socket cap screws M8*25	8	33	Hexagon socket button head screws M6*14	2
2	Flat washer d8	12	34	Heat sink	1
3	Spring washer d8	12	35	Heat sink cover	1
4	Motor assembly	1	36	Cross recess head screw M3*18	4
5	Flat key 6*20	1	37	Bakelite Washer	3
6	fixed pin	2	38	Cross recess head screw M4*16	3
7	Hook holder	1	39	Cross recess head screw M5*10	4
8	Cotter pin + Flat washer d8	2	40	Chain bag assembly	1
9	Primary pinion	1	41	Microswitch	2
10	Rolling bearing 6203-2RS	2	42	Limit plate	2
11	Brake	1	43	Cross recessed pan head self-tapping screw st4.2*10	2
12	Collar for shaft d15	1	44	Limit block	2
13	Plug	1	45	Rolling bearing 6206-2RS	2
14	Clamp $\phi 6 \times 15$ mm	2	46	Limit spring	8
15	Cross recess head screw M5*8	2	47	Chain bag base	1
16	Cable gland M16*1.5	2	48	Flat key 8*20	2
17	Pendant Cable	1	49	Hexagon socket cap screws M6*16	6
18	Hexagon socket cap screws M6*20	10	50	Chain wheel bracket	2
19	Flat washer d6	24	51	Chain wheel	1
20	Spring washer d6	24	52	Chain damper	1
21	Motor cover	1	53	Chain assembly	1
22	Hexagon socket cap screws M5*35	2	54	Tertiary gear wheel	1
23	Flat washer d5	2	55	Bearing Seal d30	1
24	Spring washer d5	2	56	Secondary gear assembly	1
25	Circuit board assembly (including fan)	1	57	Tertiary gear assembly	1
26	Spacer	2	58	Smart coaxial slide handle assembly	1
27	Hexagon socket cap screws M6*25	2	59	Hexagon socket cap screws M6*30	6
28	Chain wheel support frame	2			
29	Hexagon socket cap screws M8*70	4			
30	Cylindrical pin 6*20	2			
31	Housing	1			
32	Case cover	1			

Troubleshooting

After long-term use or improper operation, there may be a variety of faults. When the hoist fails to work, an error code appears on the uppermost edge of the hoist display, and an expanded view of the fault code is shown after pressing the Down key while the fault is active.

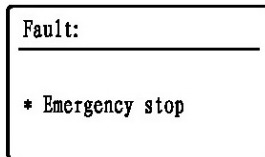
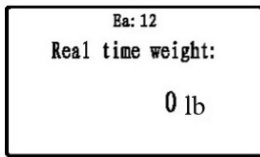

Common faults, causes and maintenance measures are shown in the following table:

Common faults	Cause	Service measures
Hoist does not turn on	(1) Power supply is not connected (2) Broken or loose wiring (3) Switch failure (4) Emergency stop switch is engaged	(1) Power on (2) Check wiring and repair (3) Repair or replace switch (4) Disengage emergency stop switch
Motor is loud and does not start properly	Power supply voltage too low or too high	Check supply voltage and frequency
Excessive noise	(1) Damaged gears or bearings (2) Debris inside gear or at rotor spline (3) Manufacturing defect	Contact manufacturer for technical support
Displayed Error Code	Error code	
	Ea: 1 Overload	Check for overload
	Ea: 2 Hall	Contact manufacturer for technical support
	Ea: 3 Sampling	Contact manufacturer for technical support
	Ea: 4 Controller high temperature	Equipment overheats and needs to be cooled before use
	Ea: 6 Overpressure	Contact manufacturer for technical support
	Ea: 7 Overcurrent	Check amperage
	Ea: 8 Stalled	Check for overloading or mechanical jamming
	Ea: 9 Lower IGBT	Replace control board
	Ea: 10 Upper IGBT	Replace control board
	Ea: 11 Drive voltage	Check input voltage, replace control board
	Ea: 12 Emergency stop	Check emergency stop switch is disengaged

This Page Intentionally Left Blank



BISON

For more information visit
www.bisonlifting.com

Bison Lifting Equipment, LLC.
425 Independence Parkway
La Porte, TX 77571

Phone: (201) 366-4812
E-mail: info@bisonlifting.com