BVH Series Electric Chain Hoist

User Manual and Maintenance Procedures



Description

Thank you for buying our BVH Series Electric Chain Hoist, please keep this manual handy for periodic maintenance and troubleshooting information. Before installation and use, be sure to read and understand the safety and care instructions mentioned in this User Manual carefully. Follow all Warnings and Safety Procedures. Ensure that the person operating the hoist has carefully read and understood the contents of this User Manual before operation. Please note: This product User Manual is subject to change without notice.

Technical Parameters

Model number	BVH series	
	040	050
Voltage	120V,60Hz	
Rated power	0.6 HP	1.4 HP
Rated current	7 A	15 A
Rated load	400 lbs	(1,000 lbs) ½ Ton
Lifting speed	0-30 ft/min	0-33 ft/min
Lifting height	16 ft	
Chain diameter	4.0mm	6.3mm
Duty Class	H4	
Ingress Protection	IP54	
Duty Rating	50% ED	
Working temperature range	32° - 104°F	
Net weight	30 lbs	67 lbs

Warnings

- (1) After removing the hoist from its box, carefully check the body of the hoist for any damage or defects. Visually inspect the pendant cable, hook, chain and in-line control handle for any damage during transport.
- (2) Ensure there is no dirt or debris on the load chain, check for kinks and knots in the chain. If the chain looks in good condition and is free of debris, attach the included suspension bar or top hook using the hardware provided. Please note it is not recommended to use the hoist without a thorough inspection of the chain first.
- (3) Ensure that pendant cable is free of obstruction from rotating or moving objects and there are no knots or kinks in the cable that could interfere with the load chain.
- (4) Do not leave the hoist unattended during operation or once a load has been lifted. Ensure the hoist does not remain under load while not in use.
- (5) This hoist is not for use in the rain or in extreme damp conditions. This hoist is not for use in explosive, flammable, or corrosive environments.
- (6) When the hoist is lifting or lowering, ensure that personnel do not move within the area of operation to prevent accidents.
- (7) This hoist should not be used for handling hot melts and should not be used in hazardous or extreme temperature environments.

Safety Guidelines

Before using this hoist, be sure to read and follow all safety guidelines:

1. Do NOT lift more than rated load of the hoist.
2. Do NOT use twisted, knotted, damaged, or worn chains.
3. Do NOT Operate a hoist which has been modified without the manufacturer's approval or without certification that it is in conformity with ANSI/ASME B30 volumes.
4. Do NOT Operate this hoist above or below the working temperature range (32°-104°F)
5. Do NOT attempt to lift more than the rated load capacity, this will cause the hoist to stop and an overload fault code to appear. When the lifting load exceeds the rated value, error code 'Ea: 1' appears on the handle display, pressing the Down button will open an expanded view of this error. If this situation occurs, stop use of the hoist immediately and reduce the load to below the rated capacity. When the overload is removed, the hoist can operate normally.
6. Do NOT exceed rated duty cycle of 50% - 10 min (i.e., 5 min of work followed by 5 min of rest). Do not use continuously. Continuous use of this hoist may lead to damage.
7. Do NOT operate unless load is centered directly under hoist.
8. Do NOT operate hoist when it is restricted from forming a straight line from hook to hook in the direction of loading.
9. Do NOT attempt to lengthen the load chain or repair damaged load chain.
10. Do NOT lift or move loads over people
11. Do NOT operate hoist unless all persons are and remain clear of the supported load.
12. Ensure the emergency stop is engaged when the hoist is left unattended.
13. Do NOT use load chain as a sling or wrap load chain around load.
14. Do NOT operate beyond the limits of the load chain travel.
15. Do NOT use the hoist to lift, support, or transport people.
16. Do NOT remove or obscure the warnings on the hoist.
17. Do NOT operate a hoist on which the safety placards or decals are missing or illegible.
18. Only use the provided hardware to mount or suspend the hoist.
19. Do NOT use the tip of the hook to support the load.
20. Do NOT use a hoist if the hook latch is missing or broken.

Installation

1. Before using the hoist, ensure the mounting hardware is attached as pictured in Figure 1-A

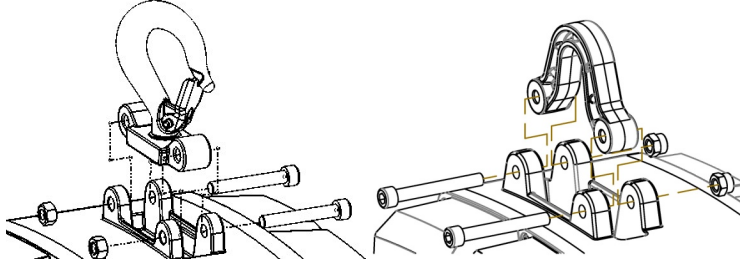

Figure 1-A
BVH-TH (Top Hook) & BVH-SB (Suspension Bar)

2. Be sure that your mounting point and its structure can support the weight of the hoist and its rated capacity. Ensure the provided hardware is used when mounting your hoist. Ensure the mounting components are installed correctly.
3. The standard power supply for the hoist operation is single-phase AC 120 (V)/60 (Hz) and must use a power supply with a ground.

Do NOT alter or modify the plug connector in any way.

Introduction of Components: See Figure 2

1. Upper hook
2. M8 self-locking nut
3. M8 * 55 internal hex screw
4. Main body
5. Pendant Controller
6. Lower hook
7. Chain bag
8. Power cord

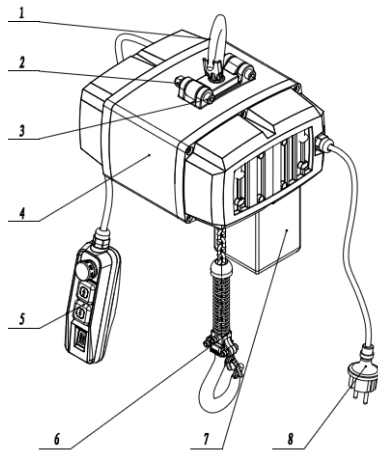

Figure 2

Operating Method

Operating the Pendant : See Figure 3

The design of the pendant control implements an infinitely variable speed control dial, that allows for extremely precise control of hook speed. The control dial has a small indicator to show where it is currently set on the spectrum of Slow (Rotate counter-clockwise) to Fast (Rotate clockwise).

This pendant also features an Emergency stop button. Pressing the emergency stop switch will engage the emergency stop function preventing the hoist from operation, to disengage, rotate the emergency stop switch clockwise.

The button will extend and disengage the emergency stop function, allowing the hoist to operate as normal. Additionally, this pendant features a digital display to show the current operation mode or any error that may occur. See Figure 3 below

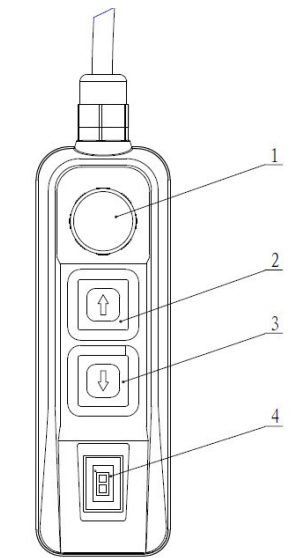

Figure 3

1. Emergency switch stop 2. Up button 3. Down button 4. Digital tube

Commented [DDdL1]: Need new figure for Dial control pendant

Chain Lubrication

New Hoists:

Before putting the hoist into operation make sure you thoroughly lubricate the chain with the oil supplied with the hoist in a small container in the packing crate. It is very common for a user to install a new hoist and make the mistake of not lubricating the chain, this quickly leads to hoist making noise or for metal shavings to fall from the hoist because the chain has been operated dry and is now damaged.

Once enough damage has occurred, it is too late to salvage the chain, requiring replacement of your new load chain.

A good quality machine or gear oil should be used to Grade ISO VG46 or 68.



Chevron Rando HD 46



Shell Tellus S2 MX 46

A Dry Lube such as CRC Dry Moly Lube can be used, found on Zoro, Amazon, MSC, Fastenal, and many other websites.



Maintenance Measures

You **MUST** periodically inspect for loose bolts nuts or rivets. Search for any evidence of wear, corrosion, or distortion, in the body, suspension bolts, load chain, and in power cords and promptly remove dust, water, and corrosive fluids that have accumulated on any part of the hoist.

Lubricating oil

A new BIH Series electric chain hoist is outfitted with a lifelong machine grease. During operation of the hoist, there may be a small amount of grease oozing, especially during the first use. This is normal and does not require the adding of any grease or lubricant to the chain hoist.

Chain

You **MUST** regularly inspect the chain components of the BIH Series electric chain hoist, and stop use if there are any of the following defects in the chain such as notches, pits, twists or kinks in the chain, welding slag, corrosion, cracks,, wear and stretched links. As shown in the figure:

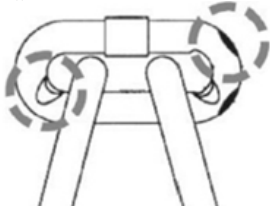

Chain specification is as follows:

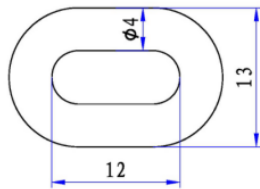

4.0mm chain size

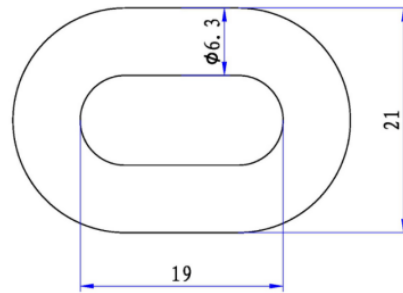

6.3mm chain size

Recommended use of original chain

Inspection of upper and lower hook:

The signs of damage to be on the lookout for when it comes to load hooks are corrosion, deformation, fracture, or distortion greater than 10° compared to a normal hook, enlarged hook opening, etc., which indicate improper use or overload of the hook. Be sure to check the hook safety latch to make sure it is not damaged or bent and remains closed when in use.

BVH-040 Electric Chain Hoist Exploded Diagram

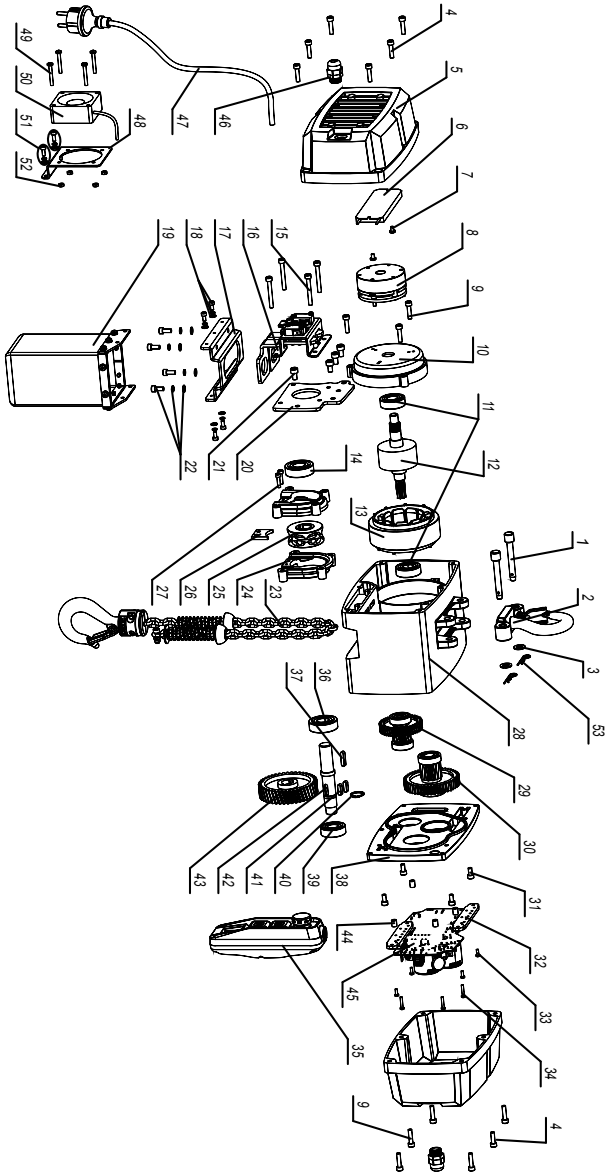

BVH-040

Details of BVH-040 Electric Chain Hoist Exploded Diagram

No.	Components	Quantity	No.	Components	Quantity
1	Mounting pin	2	28	Housing	1
2	Hook assembly	1	29	Primary gear assembly	1
3	Lock nut M8	2	30	Secondary gear assembly	1
4	Hexagon socket cap screws M5*20	7	31	Hexagon socket cap screws M5*10	4
5	Cover	2	32	Heat transfer plate	2
6	Heat Sink	2	33	Cross recess head screw M3*8	4
7	Cross recess head screw M4*6	4	34	Cross recess head screw M3*16	4
8	Brake	1	35	Handle assembly	1
9	Hexagon socket cap screws M5*30	8	36	Rolling bearing 6203-2RS	1
10	Motor rear cover	1	37	Flat key 5*22	1
11	Rolling bearing 6202-2RS	2	38	Case cover	1
12	Rotor	1	39	Rolling bearing 6202- 2RS	1
13	Stator	1	40	Retainer for axis d17	1
14	Rolling bearing 6203-2ZN + stop ring d40	1	41	Flat key 5*16	2
15	Hexagon socket cap screws M5*45	4	42	Chain wheel axis	1
16	Limit assembly	1	43	Tertiary gear wheel	1
17	Chain bag holder	1	44	Spacer	4
18	Cross recess head screw triple combination M4*8	4	45	Main control board	1
19	Chain bag	1	46	Cable gland	2
20	Support plate	1	47	Plug	1
21	Hexagon socket cap screws M6*14	4	48	Fan mounting plate	1
22	Hexagon socket cap screws triple combination M5*12	4	49	Cross recess head screw M4*30	4
23	Chain assembly	1	50	Fan	1
24	Chain wheel racket	2	51	Hexagon socket cap screws three-in-one combination M4*10	2
25	Chain wheel	1	52	All metal lock nut M4	4
26	Chain baffle	1	53	Cotter pin	2
27	Hexagon socket cap screws M4*16	2			

BVH-050 Electric Chain Hoist Exploded Diagram

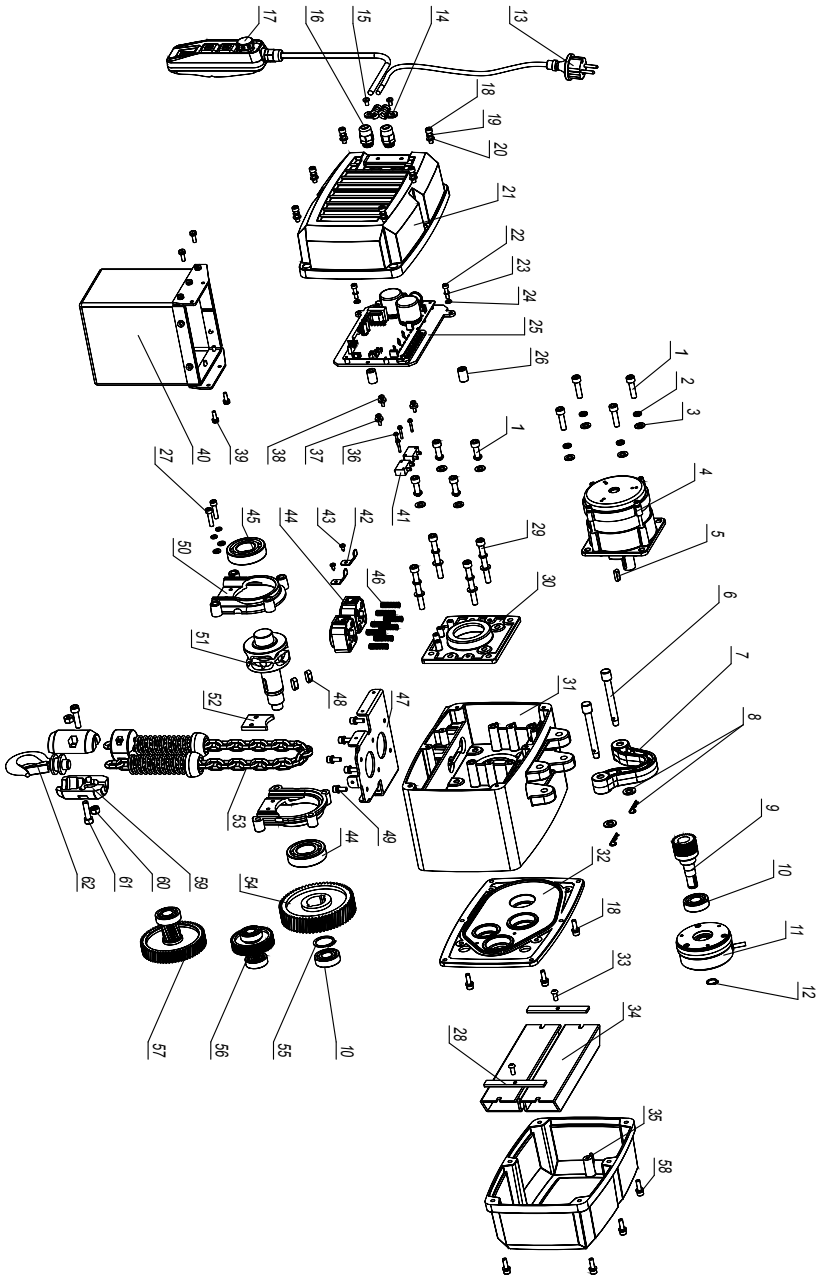

BVH-050

Details of BVH-050 Electric Chain Hoist Exploded Diagram

No.	Components	Quantity	No.	Components	Quantity
1	Hexagon socket cap screws M8*25	8	30	Cylindrical pin 6*20	2
2	Flat washer d8	12	31	Housing	1
3	Spring washer d8	12	32	Case cover	1
4	Motor assembly	1	33	Hexagon socket button head screws M6*14	2
5	Flat key 6 × 20	1	34	Heat sink	1
6	fixed pin	2	35	Cover	1
7	Hook holder	1	36	Cross recess head screw M3*18	4
8	Cotter pin + Flat washer d8	2	37	Bakelite washer	3
9	Primary pinion	1	38	Cross recess head screw M4*16	3
10	Rolling bearing 6203-2RS	2	39	Cross recess head screw M5*10	4
11	6N/M brake	1	40	Chain bag assembly	1
12	Elastic collar for shaft d15	1	41	Microswitch	2
13	Plug	1	42	Limit plate	2
14	Clamp φ6*15 mm	2	43	Pan head self-tapping screw st4.2*10	2
15	Cross recess head screw M5*8	2	44	Limit block	2
16	Cable gland M16*1.5	2	45	Rolling bearing 6206-2RS	2
17	Pendant assembly	1	46	Limit spring	8
18	Hexagon socket cap screws M6*20	10	47	Chain bag base	1
19	Flat washer d6	24	48	Flat key 8*20	2
20	Spring washer d6	24	49	Hexagon socket cap screws M6*16	6
21	Motor cover	1	50	Chain wheel bracket	2
22	Hexagon socket cap screws M5*35	2	51	Chain wheel	1
23	Flat washer d5	2	52	Chain damper	1
24	Spring washer d5	2	53	Chain assembly	1
25	Circuit board assembly	1	54	Tertiary gear wheel	1
26	Spacer	2	55	Elastic retainer ring for shaft d30	1
27	Hexagon socket cap screws M6*25	2	56	Secondary gear assembly	1
28	Chain wheel support frame	2	57	Tertiary gear assembly	1
29	Hexagon socket cap screws M8*70	4	58	Hexagon socket cap screws M6*30	6

Troubleshooting

After long-term use or improper operation, there may be a variety of faults. When the hoist fails to work, an error code appears on the hoist display

Common faults	Cause	Service measures
Hoist does not turn on	(1) Power supply is not connected (2) Broken or loose wiring (3) Switch failure (4) Emergency stop switch is engaged	(1) Power on (2) Check wiring and repair (3) Repair or replace switch (4) Disengage emergency stop switch
Motor is loud and does not start properly	Power supply voltage too low or too high	Check supply voltage and frequency
Excessive noise	(1) Damaged gears or bearings (2) Debris inside gear or at rotor spline (3) Manufacturing defect	Contact manufacturer for technical support
Handle Nixie display tube digital	A: Indicates an emergency stop.	Rotate clockwise to release emergency stop
	—: Indicates that the hoist is functioning normally;	
	0: Indicates that the button is pressed at the same time;	Release one of the buttons
	1: Overload	Weight reduction
	2: Abnormal driving voltage	Check voltage
	3: IGBT fault	Contact the manufacturer for technical support.
	4: Locked-rotor	Check for overloading or mechanical jamming
	5: Over-current	Check amperage
	6: Over-pressure	Check voltage or brake resistance
	7: High temperature	Equipment overheated and needs to be cooled before use
8: Sampling abnormality	Contact the manufacturer for technical support.	
9: Hall abnormality	Contact the manufacturer for technical support.	
Emergency stop switch	Pressing emergency stop switch can temporarily relieve problems 1, 2, 4, 5, 6	
Other matters	Contact Manufacturer for Technical Support	

This Page Intentionally Left Blank

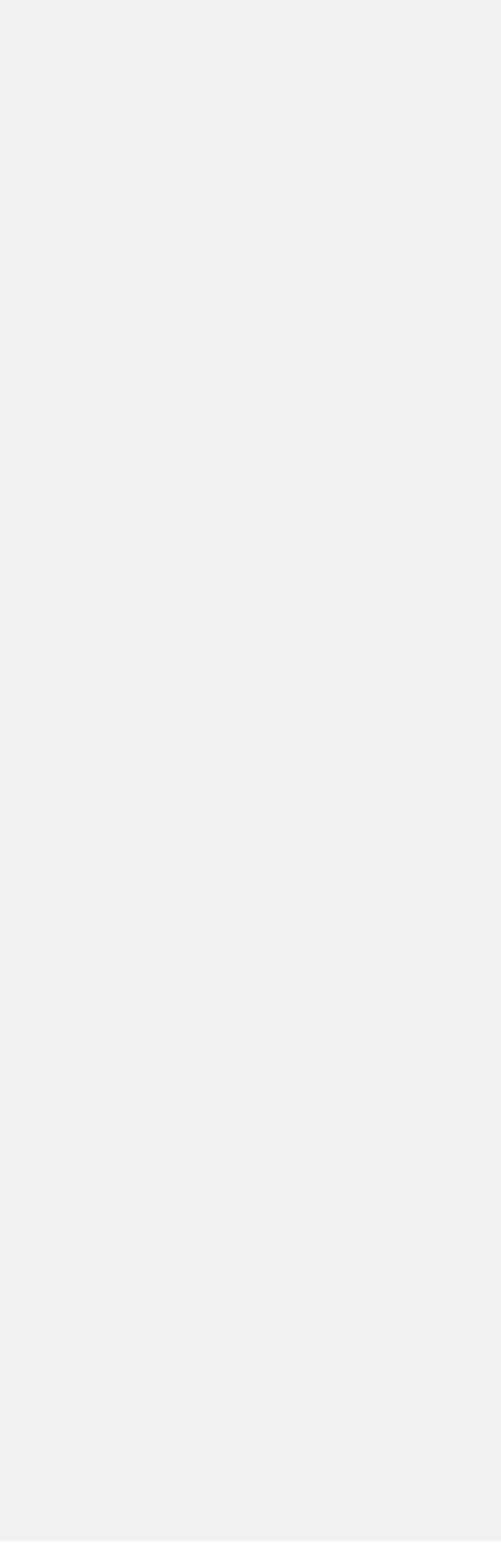



BISON

For more information visit
www.bisonlifting.com

Bison Lifting Equipment, LLC.
425 Independence Parkway
La Porte, TX 77571

Phone: (201) 366-4812
E-mail: info@bisonlifting.com